

STEAM COIL INSTALLATION, OPERATION AND MAINTENANCE

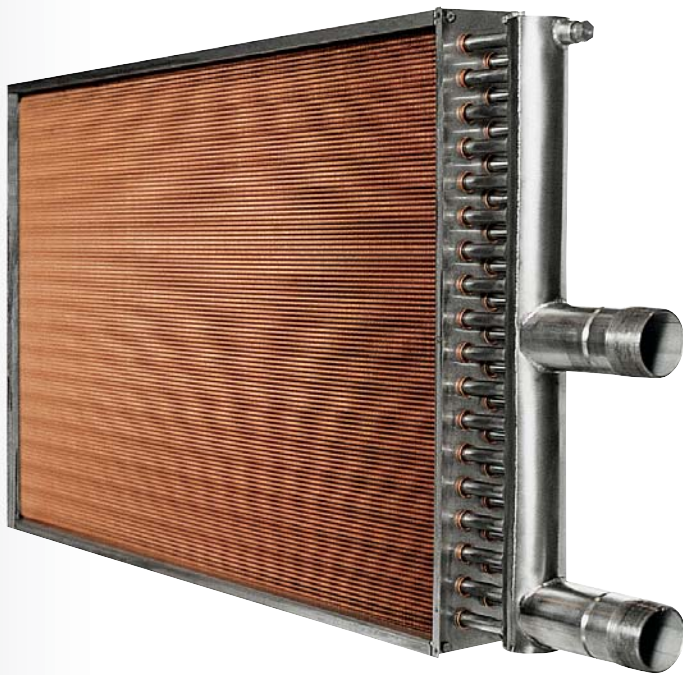

Guidelines for the installation, operation and maintenance of the Heatcraft brand of steam heating coils manufactured by Modine in Grenada, MS have been provided to help insure proper performance of the coils and their longevity. These are general guidelines that may have to be tailored to meet the specific requirements of any one job. As always, a qualified party or individual should perform the installation and maintenance of any coil. Protective equipment such as safety glasses, steel toe boots and gloves are recommended during the installation and routine maintenance of the coil.

CAUTION! Steam, even at low pressure, can cause serious bodily injury that may result in death. Be sure the system is off or the components are isolated before beginning work

RECEIVING INSTRUCTIONS

All Heatcraft coils are factory tested, inspected and carefully packaged.

Damage to the coils can occur after they have left the factory. Therefore, the coils should be inspected for shipping damage upon receipt. The freight bill should also be checked against items received for complete delivery. Damaged and/or missing items should be noted on the carrier's freight bill and signed by the driver.

For additional assistance, contact your local Modine coil representative.

Heatcraft[®] steam coils



NOMENCLATURE AND MOUNTING

NOMENCLATURE

5 SA 12 01 C 24.00 x 144.00

5 = Tube O.D.

5 = 0.625" or 8 = 1"

SA = Coil Type

Distributing Tube

5JA, 8JA: same end conn

5GA, 8GA: same end conn (high pressure)

5DA, 8DA: dual supply, opp end conn

5LA, 8LA: dual supply, opp end conn (high pressure)

5RA, 8RA: opp end conn

5TA, 8TA: opp end conn (high pressure)

Single Tube

5SA, 8SA: opp end conn

5HA, 8HA: opp end conn (high pressure)

5SB: opp end conn, 3" center-to-center

5HB: opp end conn, 3" center-to-center (high pressure)

5SS: same end conn

5SH: same end conn (high pressure)

12 = Fins Per Inch

01 = Rows

C = Fin Design

A - flat (Al, Cu)

B - corrugated (Al, Cu)

C - sine wave (Al, Cu)

F - flat (SS, CS)

G - corrugated (SS, CS)

H - sine wave (SS, CS, Al, Cu)

24.00 = Finned Length (inches)

144.00 = Fin Height (inches)

MOUNTING

Steam coils must be properly mounted for condensate removal.

This will aid in preventing destructive water-hammer, keeping coils from freezing, and preventing corrosive elements from collecting in the tubes. Pitched case coils should be installed level as shown in Figure 1a - Pitched in Case.

Models SA, SB, HA, JA, GA, DA, LA, RA and TA come standard pitched in the casing. Models SS and SH utilize return bend construction and are not pitched in the casing, but need to be installed level as in Figure 1a. Coils that are unpitched, must be installed with the tubes pitched towards the return connection as shown in Figure 1b (with the exception of models SS and SH). A minimum pitch of 0.125" per foot of coil length is required (pitch has been exaggerated in Figure 1b for illustration to show a case that was not pitched). Unless otherwise requested, all Heatcraft steam coils shall be pitched in case 0.125"/ft. as shown in Figure 1a.

Figure 1a. Pitched in Case

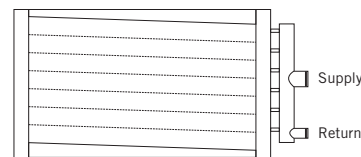

Figure 1b. Unpitched in Case

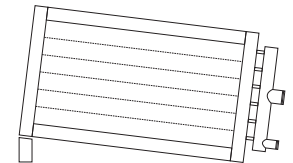
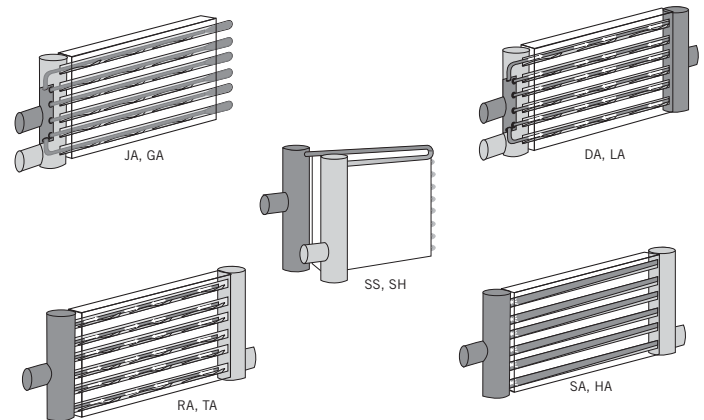

Figure 2. Steam Coils



COIL TYPES

COIL TYPES

Distributing

Models JA, RA and DA jet-tube steam distributing coils are excellent for any general purpose heating application. With the superior freeze resistance provided by the tube-within-a-tube construction, it is ideal for low temperature preheating and special process applications. The construction features inner tubes with directional orifices to aid in steam distribution and condensate removal. Model JA offers same-end supply and return connections. Model RA offers opposite-end supply and return connections. Model DA offers dual-supply opposite-end connections for long coils that see sub-freezing air temperatures. Models GA, TA and LA utilize cupro-nickel, carbon steel and stainless steel tubing for high-pressure construction.

Single Tube

Model SA steam coil is designed for general purpose heating. The construction features a single tube design with opposite-end supply and return connections. A perforated baffle located directly behind the supply connection insures proper steam distribution. Model HA utilizes cupro-nickel, carbon steel and stainless steel tubing for high-pressure construction.

Standard Steam

Model SS steam coil features return-bend construction and same-end connections. Model SH utilizes cupro-nickel, carbon steel and stainless steel tubing for high-pressure construction.

Figure 3. Steam Horizontal Coil Piping Diagram

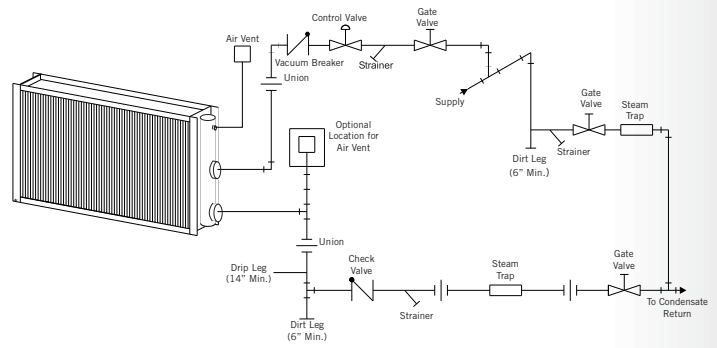

Note 1: Vacuum breakers and air vents should be piped to a drain or other suitable location where discharged steam cannot lead to personal injury.

Figure 4: Steam Vertical Coil Piping Diagram

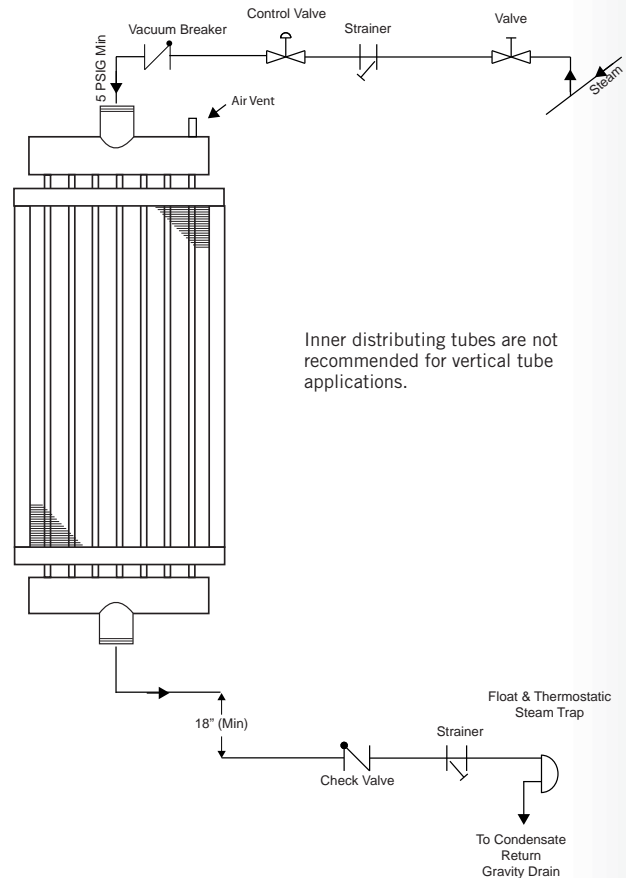

Note: If there is back pressure in the condensate return line or if the condensate line is elevated higher than the steam trap, then a pressure powered pump is required in order to drain coil at all times.



INSTALLATION AND OPERATION

INSTALLATION

1. Carefully remove the coil from the shipping package to avoid damage to the finned surface area. Damaged fins can be straightened using an appropriate fin comb.
2. Heatcraft recommends cleaning the coil with a commercially available coil cleaner prior to installation. Refer to Maintenance on Page 4 for cleaning recommendations.
3. Mount coil properly to insure positive condensate drainage. Refer to Mounting instructions on page 1.
4. Proper clearance should be maintained between the coil and other structures such as the fan, filter racks, transition areas, etc.
5. Utilize vacuum breakers on each coil. Steam traps require a positive pressure differential to force the condensate through the valve seat. If the coil's pressure drops below atmospheric, the pressure differential across the valve will be negative and the condensate will not drain. This condition can lead to serious damage or failure of the coil due to freezing, water hammer and corrosion. Refer to piping diagram for recommended placement. See Note 1 in Figure 3 - Steam Horizontal Coil Piping Diagram on Page 2.
6. Trap each coil separately. Differences in pressure from coil to coil can result in the backing-up of condensate which will result in poor coil performance and possible damage.
7. Provide an air vent for each coil at its highest location. Modine provides a 0.5" threaded vent connection on the return manifold as a standard on all steam coils. Non-condensable gasses present in the steam will collect in a coil and reduce its capacity. Therefore, it is necessary to provide a means for the removal of these gasses. Also, these gasses can diffuse into the condensate forming byproducts, which can lead to severe corrosion. See Note 1 in Figure 3 - Steam Coil Piping Diagram on Page 2.
8. Steam supply lines need to be drained of condensate. This can be accomplished by the use of drip legs. This ensures that high quality steam enters the coil.
9. Condensate return piping should be the same size as the coil's return connection from the coil outlet to the steam trap. Not following this guideline could result in the coil to become filled with condensate and the system to "stall". For more information on steam stall, see page 4.
10. Once installed, the coil should be pressurized to 100 psig with dry nitrogen or other suitable gas. The coil should be left pressurized for a minimum of 10 minutes. If the coil holds the pressure, the field connections can be considered leak free. If the pressure drops by 5 psig or less, re-pressurize the coil and wait another 10 minutes. If the pressure drops again, there are more than likely one or more small leaks, which should be located and repaired. Pressure losses greater than 5 psig would indicate a larger leak, which should be isolated and repaired. Be sure to check valves and fittings as potential sites for leakage or bleed.
11. All field brazing and welding should be performed using high quality materials and an inert gas purge (such as nitrogen) to reduce oxidation of the internal surface of the coil.

12. All field piping must be self supporting. System piping should be flexible enough to allow for thermal expansion and contraction of the coil. The use of flexible connections and/or swing joints is recommended.
13. The coil along with the control valve and trap should be isolated by manual valves to allow for servicing.
14. For horizontal coil installation, refer to Figure 3 - Steam Horizontal Coil Piping Diagram on Page 2 for general piping.
15. For vertical coil installation, refer to Figure 4 - Steam Vertical Coil Piping Diagram on Page 2 for general piping.
16. Inner distributing tubes are not recommended for vertical tube applications.
17. If you are unsure about any portion of the installation, contact your local steam specialist for assistance. Failure to properly install the coil can result in irreparable damage to the coil as well as other components in the system.

OPERATION

1. Proper airflow distribution is vital to coil performance. Air-flow anywhere on the coil face should not vary by more than 20%.
2. Air velocities should be maintained between 200 and 1500 feet per minute.
3. Operating pressures must be at or below the maximum operating pressure for that coil at the steam temperature. Pressure and temperature limitations can be determined through Modine's Pressure and Temperature program. Contact your local Modine coil representative for assistance.



MAINTENANCE AND SYSTEM STALL

MAINTENANCE

1. Scheduled plant maintenance should include the draining and flushing of the condensate drip legs and sediment traps as well as inspection of condensate traps, vacuum breakers, air vents and valves. Boiler water analysis should also be performed on a regular basis.
2. To continually deliver optimum heating capacity, both the external and internal heat transfer surfaces must be maintained as clean and corrosion free as possible. The finned surface can be maintained by the use and constant inspection of pre-filters. The filters should be replaced as needed.
3. Should the finned surface become fouled, the coil can be cleaned utilizing commercially available coil cleaning fluids. Caution should be exercised in selecting the cleaning solution as well as the cleaning equipment. Improper selection can result in damage to the coil and/or health hazards. Be sure to carefully read and follow the manufacturer's recommendations before using any cleaning fluid. Clean the coil from the leaving air-side so that foreign material will be washed out of the coil rather than pushed further into the coil.
4. Internal coil maintenance consists primarily of preventing scale and corrosion. This is accomplished through aggressive boiler water treatment, removal of dissolved oxygen and the removal of non-condensable gasses such as carbon dioxide.

NOTE! Boiler water treatment is beyond the scope of this manual. Contact your local water treatment specialist for assistance in establishing a proper boiler-water treatment program.

SYSTEM STALL

“System stall” is lack of positive differential across the steam trap, and temperature controlled equipment will always be subject to this problem when the trap must operate against back pressure.

Under these conditions, a vacuum breaker is ineffective because “stall” always occurs above atmospheric pressure. Even when steam is supplied at a constant pressure or flow to “batch” type equipment, stall can occur for some period of time on startup when the steam condenses quickly and the pressure drops below the required differential. What happens when the system stalls is that the effective coil area drops as the steam chamber floods and heat transfer is reduced until the control valve responds to deliver an excessive supply of steam to the coil. This results in a “hunting system” with fluctuating temperatures and hammering coils as the relatively cooler condensate alternately backs up, then at least some portion is forced through the trap. This hunting occurs on the milder temperature days because the coil is sized for the lowest possible air temperature. The coil cannot change surface area, so the steam pressure/temperature control valve takes over to accommodate the change in load.

The solution to all system stall problems is to make condensate drain by gravity under all conditions including vacuum. Atmospheric systems tend to operate more predictably and are generally easier to control but major heating equipment is usually not

drained into an atmospheric return because of the large amount of energy that is lost from the vent.

PRIMARY TYPES OF DRAINAGE SYSTEMS

1. Gravity drain to atmospheric (OPSIG) condensate return with no elevation after the steam trap. This gravity drainage system must assure that there is never pressure above atmospheric in the condensate return. CAUTION, failed open steam traps and other leaks from the steam piping to the condensate return piping will pressurize the condensate return enough to cause steam stall.

High temperature/pressure condensate will flash back into steam immediately downstream of the steam traps and cause back pressure on the steam traps draining the coil causing steam stall.

Condensate return lines designed for atmospheric pressure must be adequately sized to allow for the flash steam and condensate. They must be pitched toward the condensate receiver which is vented to atmosphere. The vent line off of the atmospheric receiver must be sufficient size to vent all flash steam without building up a back pressure in receiver.

2. Closed loop system using an Automatic Pump Trap. To make equipment drain by gravity against back pressure, the steam trap should be replaced by an Automatic Pump Trap (APT). In this arrangement, the equipment does not have a vacuum breaker but is pressure equalized to drain by gravity to the APT, then the equalizing line is isolated while condensate is pumped from the system.

This arrangement will drain the coil free of condensate at all times (even under a vacuum). If there is sufficient differential pressure to move the condensate through the APT then it functions as a normal steam trap. Then when needed it functions as a pump, using steam as a motive force to move the condensate to the condensate system.

The APT is a simple and efficient solution to a difficult problem. Without the need for high Net Positive Suction Head NPSH, the APT will operate with only 8” installation head from the base of the pump, and remove condensate from a coil under vacuum, atmospheric or higher pressures, discharging to either high or low level condensate return lines.



Luvata Grenada LLC
Tel: 800-225-4328
Fax: 662-229-4212
Grenada, MS
Email: coils@modine.com

