

## FLUID COIL INSTALLATION, OPERATION AND MAINTENANCE



Guidelines for the installation, operation and maintenance of the Heatcraft brand of fluid cooling and heating coils manufactured by Modine in Grenada, MS have been provided to help insure proper performance of the coils and their longevity. These are general guidelines that may have to be tailored to meet the specific requirements of any one job. As always, a qualified party or individual should perform the installation and maintenance of any coil. Protective equipment such as safety glasses, steel toe boots and gloves are recommended during the installation and routine maintenance of the coil.

### RECEIVING INSTRUCTIONS

All Heatcraft coils are factory tested, inspected and carefully packaged.

Damage to the coils can occur after they have left the factory. Therefore, the coils should be inspected for shipping damage upon receipt. The freight bill should also be checked against items received for complete delivery. Damaged and/or missing items should be noted on the carrier's freight bill and signed by the driver.

For additional assistance, contact your local Modine coil representative.

Heatcraft<sup>®</sup> heat transfer coils



# NOMENCLATURE AND INSTALLATION

## NOMENCLATURE

**5 W S 14 06 C 24.00 x 144.00**

### 5 = Tube O.D.

3 = 0.375"  
4 = 0.500"  
5 = 0.625"

### W = Coil Type

W = Standard Fluid  
M = Splayed Headers  
B = Booster  
K = Cleanable Both Ends  
P = Cleanable Supply End  
Q = Cleanable Opp. Supply End

### S = Circuiting

I = 1/6 serp C = 1 1/4 serp  
Q = 1/4 serp P = 1 1/3 serp  
E = 1/3 serp M = 1 1/2 serp  
H = 1/2 serp D = 2 serp  
G = 2/3 serp T = 3 serp  
L = 3/4 serp F = 4 serp  
S = 1 serp B = skip tube

### Booster

S = 1 circuit  
D = 2 circuits  
B = skip tube

### 14 = Fins Per Inch

### 06 = Rows Deep

### C = Fin Design



A - flat (Al, Cu)  
B - corrugated (Al, Cu)  
C - sine wave (Al, Cu)  
D - raised lance (Al) 3/8 only  
F - flat (SS, CS)  
G - corrugated (SS, CS)  
H - sine wave (SS, CS, Al, Cu)

### 24.00 = Fin Height (in)

### 144.00 = Finned Length (in)

## MOUNTING

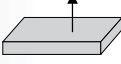
All water and glycol coils are designed to be fully drainable when properly mounted. Vertical air-flow is not recommended for dehumidifying coils.

	Horizontal Air Flow Horizontal Tubes	Level with the Y-axis & X-axis
	Vertical Air Flow <sup>2</sup> Horizontal Tubes	Level with the Z-axis & X-axis
	Horizontal Air Flow Vertical Tubes	Level with the Y-axis & X-axis

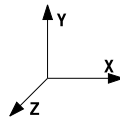

## COIL TYPES

**Standard Fluid Coils** - Our fluid coils are specifically designed for your particular fluid application. Flexibility is built into our manufacturing processes, offering variations in fin type, fin density, circuitry arrangement, coil casing and materials of construction. Standard fluid type "W" coils utilize a collection header for one and two row applications and return bends for applications that require three or more rows. Type "M" coils are used for one and two row applications that require same end connections. For type "M" coils the supply and return headers are offset or "splayed." This orientation allows for the supply and return headers to be placed side by side. Booster coils, type "B," are also available for one and two row applications.

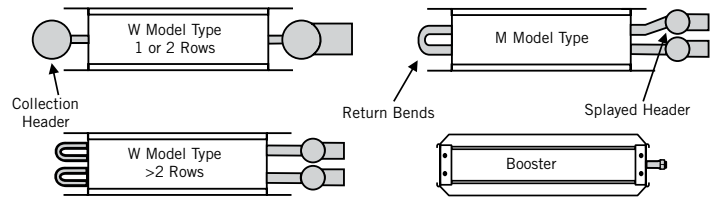

**Cleanable Fluid Coils** - We offer cleanable fluid coils for applications where mechanical cleaning of the internal surface of the tubes is needed. Our cleanable coils utilize a box-style head in lieu of cylindrical headers. The head contains baffles for circuiting and is removable for easy access to coil tubes. Type "P" coils are cleanable from the supply end of the coil. Type "Q" coils are cleanable from the end opposite the supply. Type "K" coils are cleanable from both ends of the coil.

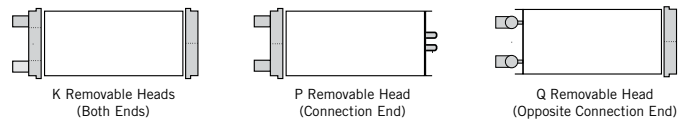

## INSTALLATION

1. Carefully remove the coil from the shipping package to avoid damage to the finned surface area. Damaged fins can be straightened using an appropriate fin comb. If a mist eliminator was purchased, remove it before installation. See Figure 3 on Page 3.
2. For coils with removable heads, check the torque on the nuts before installing. Refer to Maintenance on Page 3 for recommended torque values.
3. Modine recommends cleaning the coil with a commercially available coil cleaner prior to installation. Refer to Maintenance on Page 3 for cleaning recommendations.

# INSTALLATION CONTINUED

- Check the coil hand designation to insure that it matches the system. Water and glycol coils are generally plumbed with the supply connection located on the bottom of the leaving air-side of the coil and the return connection at the top of the entering air-side of the coil. This arrangement provides counter flow heat exchange and positive coil drainage. If a universal coil is supplied, cap off the two unused connections.

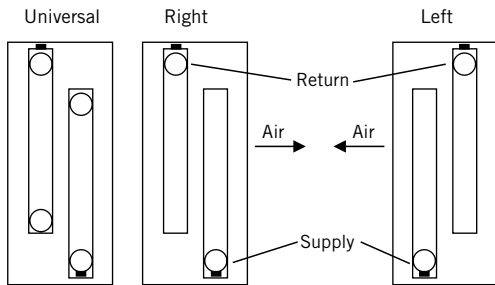

- Standard coils must be mounted level to insure drainability. Refer to Mounting on page 1 for leveling requirements. Coils with intermediate headers and coils with removable box style headers can be pitched 0.125" per foot of coil finned length towards the coil's header/connection end.
- Proper clearance should be maintained between the coil and other structures such as the fan, filter racks, transition areas, etc..

- Once installed, the coil should be pressurized to 100 psig with dry nitrogen or other suitable gas. The coil should be left pressurized for a minimum of 10 minutes. If the coil holds the pressure, the hook-up can be considered leak free. If the pressure drops by 5 psig or less re-pressurize the coil and wait another 10 minutes. If the pressure drops again, there is more than likely one or more small leaks which should be located and repaired. Pressure losses greater than 5 psig would indicate a larger leak that should be isolated and repaired. If the coil itself is found to be leaking, contact your local Modine coil representative.
- All field brazing and welding should be performed using high quality materials and an inert gas purge (such as nitrogen) to reduce oxidation of the internal surface of the coil.
- All field piping must be self supporting. System piping should be flexible enough to allow for thermal expansion and contraction of the coil.
- General piping diagrams can be found in Figure 1 - Horizontal Airflow and Figure 2 - Vertical Airflow.
- If a mist eliminator was purchased with the coil installed, place the mist eliminator into its brackets. Make sure the mesh is aligned with the coil finned area (Figure 3 Mist Eliminator).

Figure 1. Horizontal Airflow

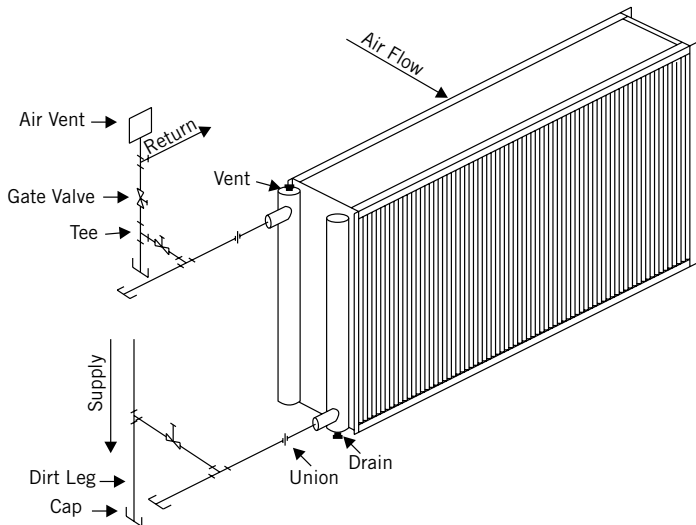
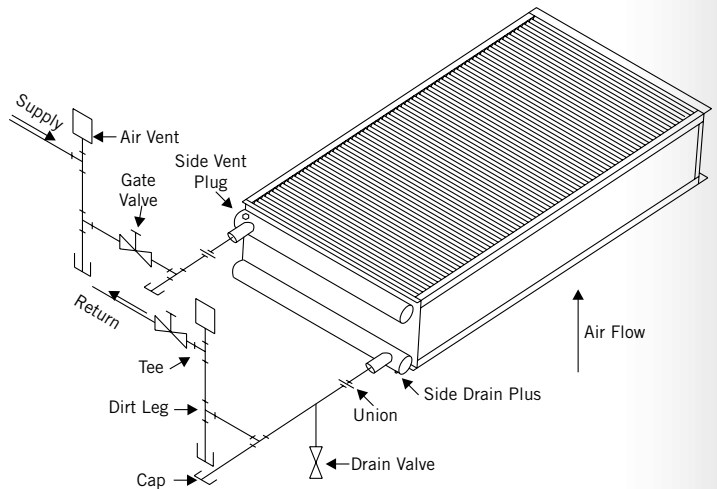
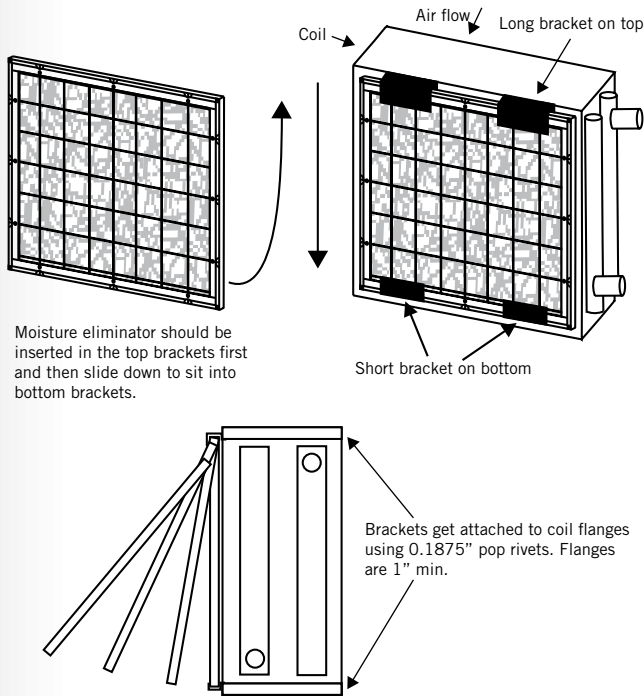

Figure 2. Vertical Airflow



# OPERATION AND MAINTENANCE

Figure 3. Mist Eliminator Installation



## OPERATION

### Initial Start-Up

1. Open all air vents so that air is eliminated from within the coil circuitry and headers. Verify that all vents and drains are not obstructed and do discharge a stream of water.
2. Fill the coil with water then close all vents.
3. Perform an initial hydrostatic leak test of all brazed, threaded or flanged joints, valves and interconnecting piping. Recheck the coil level and correct if necessary. When the setup is found to be leak free, discharge and discard initial water charge. It is important that all grease, oil, flux and sealing compounds present from the installation be removed.

### General

1. Proper air distribution is vital to coil performance. Air flow anywhere on the coil face should not vary by more than 20%.
2. The drain pan and associated piping (drain line and trap) should be installed so that there is no standing water in the drain pan and that no blow-through occurs.
3. Fluid and air velocities should be maintained within our recommended values.

Fluid Velocity		Air Velocity	
Water	1 to 8 fps	Cooling	Dry Surface: 200-800 fpm Wet Surface: 200-550 fpm
Glycol	1 to 6 fps	Heating	200-1500 fpm

## MAINTENANCE

### General

1. Filters and mist eliminators should be inspected on a regular basis and changed as needed. Maintaining clean filters and mist eliminators is a cost effective way to help maintain maximum coil performance and service life.
2. Periodic inspection of the coil for signs of corrosion and/or leaks is recommended. Repair and replacement of the coil and the connection of piping, valves, etc., should be performed as needed by a qualified technician.
3. Should the coil surface need cleaning, caution must be exercised in selecting the cleaning solution as well as the cleaning equipment. Improper selection can result in damage to the coil and/or health hazards. Clean the coil from the leaving air-side so that foreign material will be washed out of the coil rather than pushed further in. Be sure to carefully read and follow the manufacturer's recommendations before using any cleaning fluid.
4. The circulated fluid must be free of sediment, corrosive products and biological contaminants. Periodic testing of the fluid followed by any necessary corrective measures along with maintaining proper fluid velocities and filtering of the fluid will help to satisfy this goal.
5. If automatic air vents are not utilized, periodic venting of the coil is recommended to remove accumulated air. Caution should be exercised to avoid injury. High pressure and/or high temperature fluids can cause serious personal injury.
6. Cleanable coils with removable box headers should be cleaned using a suitable brush or its equivalent. Dislodged debris should be flushed from the coil and drain pan. Be sure that debris does not clog the drain. After the coil has been cleaned, the old gaskets should be discarded and replaced with new ones (contact your local Modine coil representative for replacement gaskets). The box header should then be reinstalled. The recommended installation procedure is as follows.
  - a. Nuts and weld studs should be coated with thread lubricant.
  - b. Tighten all nuts per Figure 4 - Torque Pattern, to 35 ft-lb torque. After the initial torque has been applied retorque them to 50 ft-lb, again using the pattern shown in Figure 4. The permissible range of final torque values are as follows:

maximum torque: 53 ft-lb  
 design torque: 50 ft-lb  
 minimum torque: 47 ft-lb

Figure 4. Torque Pattern

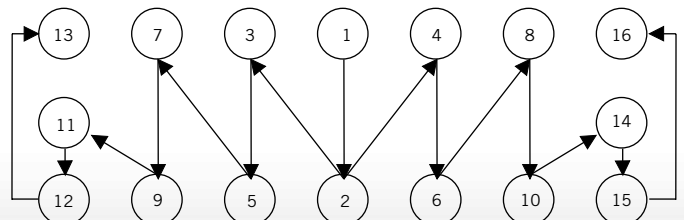

# MAINTENANCE, FREEZE PROTECTION, FLUSHING COILS

- c. Pressure test coils per the installation instructions.
- d. After the coil has been leak tested and found to be free from leaks, let it sit for 24 hours. Retorque to 50 ft-lb per Figure 4 - Torque Pattern.
- e. Refill the coil per the operation instructions.

## FREEZE PROTECTION

During the winter, chilled water coils need to be protected against freezing. The two predominant protective measures are blowing out coils and flushing coils. Both are covered next.

### Blowing-Out Coils

1. Isolate the coil from the rest of the system by closing the valves on both the supply and return lines (gate valves in Figure 1 - Horizontal Airflow and Figure 2 - Vertical Airflow on Page 2).
2. Drain the coil by opening all drain valves and/or the drain plug. Remove the vent plug to aid the draining process.
3. Once the coil has been fully drained, the blower can be hooked-up. Caps installed in the piping on straight runs going to the supply and return connections are ideal points to hook-up the blower. The air vent and drain plug are not suitable locations for hooking-up the blower. Caution should be exercised when installing the blower. The blower operator must take precautions to insure that water does not come into contact with any of the electrical components of the blower. Failure to do so may result in damage to the equipment and serious injury.
4. Close the vent or drain plug on the header which the blower is connected and open the drain valve or cap on the other header.
5. Operate the blower for 45 minutes and then check the coil to see if it is dry. A mirror placed in the discharge will become fogged if moisture is present. Repeat this procedure until the coil is dry.
6. Let the coil stand for several minutes then blow it out again. If water comes out, repeat the blowing operation.
7. Leave all plugs out and drains open until the threat of freezing has passed.

### Flushing Coils

1. We recommend the use of inhibited glycol designed for HVAC applications for corrosion protection. The use of uninhibited glycol has produced formicary corrosion in copper tubing. The complete filling of water coils with an inhibited glycol solution for freeze protection can be expensive. In some instances, it is more cost effective to flush the coils with an appropriate concentration of inhibited glycol solution. Residual fluid can be left in the coil without the threat of freeze damage provided the correct concentration of inhibited glycol was used. The recovered fluid can then be used to flush other coils. Select an inhibited glycol solution that will protect the coil from the lowest possible temperatures that can occur at the particular coil's locality. The following tables have been provided for your convenience.

% Ethylene Glycol by Volume	Freeze point <sup>1</sup>	% Propylene Glycol by Volume	Freeze point <sup>1</sup>
0	32°F	0	32°F
10	25°F	10	26°F
20	16°F	20	19°F
30	3°F	30	8°F
40	-13°F	40	-7°F
50	-34°F	50	-28°F
60	-55°F	60	-60°F

<sup>1</sup>Freeze points may vary from product to product.

2. Estimate the volume of the coil in gallons. For 0.625" tubes with 1.5" face tube spacing.  
fin height (in) x finned length (in) x # of rows x 0.0011 = gallons  
For 0.5" tubes (1.25" face tube spacing)  
fin height (in) x finned length (in) x # of rows x 0.00083 = gallons
3. Isolate the coil from the rest of the system by closing the valves on both the supply and return lines (gate valves in Figure 1 - Horizontal Airflow and Figure 2 - Vertical Airflow on Page 2).
4. Drain the coil by opening all drain valves and/or the drain plug. Remove the vent plug to aid the draining process.
5. Close the drain valve(s) and drain plug.
6. Connect the flushing system to the coil. A typical system is shown in Figure 5 - Flushing System Diagram.
7. With the throttling valve closed, start the pump and operate until the air is vented from the coil. Next, close the air vent.
8. Open the throttling valve about half-way and circulate the fluid through the coil for 15 minutes. Check the strength of the fluid. A hydrometer or test kit from the fluid manufacturer is suitable for this application.
9. Adjust the solution strength as needed and circulate the fluid for another 15 minutes.
10. Repeat steps 8 and 9 until the desired concentration is reached.
11. Shut the pump down and drain the inhibited glycol from the coil.
12. The recaptured fluid can be used to flush other coils.

**NOTE!** Be sure to follow the manufactures' recommendations before utilizing any glycol based antifreeze solution. Additional fluid will be required for the pump, connected piping and fluid reservoir. Formulas are for estimation purposes only.

Figure 5. Flushing System Diagram

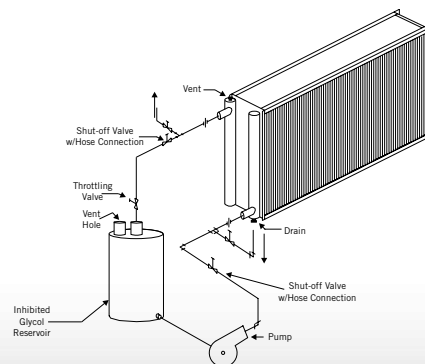



Modine Grenada LLC  
Tel: 800-225-4328  
Fax: 662-229-4212  
Grenada, MS  
Email: [coils@modine.com](mailto:coils@modine.com)

